

### Other CruzPro Products

- Depthsounders & Speed/Temperature/Logs
- PC Based Fishfinders and Active Depth Transducers
- DC Volts/Amps/Amp-Hour Monitor
- AC Volts/Amps/Freq/kW Monitor
- LPG/Petrol Gas Detectors/Alarms
- Bilge Water Alarms & Smart Bilge Pump Controllers
- Windlass Controller/Chain Counter
- Digital Fuel Gauge & Fuel Consumption Calculator
- Digital Gauge for Three Tanks /w Separate Alarms
- Four Step Smart Alternator Regulators
- Marine Security System
- RPM/Engine Hours/Elapsed Time Gauges
- Digital Oil Pressure Gauge/Alarm
- Digital Water Temperature Gauge/Alarm
- One and Three Bank Digital Volts and Amps Gauges
- Digital Clock/Watch/Race Timers/Alarms
- 8 and 16 Amp Light Dimmers / Motor Speed Controller
- Solar Panel Charge Controllers 6/8/9 & 20 Amps
- 4 & 8 Channel NMEA Combiners/RS-232 Convertors
- Engine/Exhaust Temp. Monitor & Digital Pyrometer
- Remote Digital NMEA 0183 Data Repeaters

CruzPro®  
FU60

CE



Intelligent Digital Fuel Gauge/w  
Alarms & Consumption Calculator

key again results in the next set of data being displayed.

To leave the data editor, use the ▲ key to scroll to the word "dONE" and press the + key to exit.

Selecting USA or European Default Sender

In order for the gauge to be usable before calibration, a default set of tank calibration and sender data is factory pre-programmed into the FU60 fuel gauge.

The factory default setup for the FU60 is for a 100.0 gallon or liter tank with a 10-180 ohm American type sender. To switch between 10-180 ohm USA and 240-33 ohm European type sender, press and hold the ▼ key for five seconds when power is applied (until you see the "USA" or "EU" letters). Use the ▼ and ▲ keys to switch between USA and EU and press the + key to save your entry.

Page 18

### Introduction

The FU60 digital fuel gauge provides a highly accurate display of fuel remaining, trip fuel, total fuel used, fuel consumption rate and "Time-To-Go" at current rate.

Fuel can be displayed with a resolution of 0.1 liters or gallons or as a percentage (0 to 100%). The FU60 "learns" your tank and fuel sender characteristics and is accurate with any tank shape. It is compatible with all popular resistive fuel senders, both American and European. Low and High Fuel alarms can be set and the built-in 85 dB alarm will sound and the display will flash.

Five levels of backlighting can be selected and all setup, calibration constants, alarm values, etc. are saved in a nonvolatile memory. The FU60 outputs NMEA 0183 serial data or this terminal may be programmed to activate an external alarm or fuel transfer pump if using a day tank. The FU60 contains a full data editor that can be used to edit (not enter) the fuel data & sender resistance values.

Page 3

## Table of Contents

Introduction .....	3
Specifications .....	4
Installation .....	5
Operation .....	8
Key Functions .....	8
Backlight Intensity .....	9
Setting Low/High Fuel Alarms .....	9
Enabling/Disabling Alarms .....	10
Checking Fuel Remaining .....	10
Checking Total Fuel Used or Trip Fuel Used .....	11
Checking/Resetting Fuel Consumption Rate .....	11
Checking "Time-To-Go" at Current Consumption Rate ..	12
Setup and Calibration .....	13
Select NMEA, External Alarm or Fuel Transfer Mode ...	16
Fuel/Sender Data Editor Operation .....	17
Selecting USA or European Default Sender .....	18

**VERY IMPORTANT Notes** . . . . . 19

Other CruzPro Products . . . . . 20

©1999 CruzPro Ltd.

FU60MAN-P

[www.cruzpro.com](http://www.cruzpro.com)

[info@cruzpro.com](mailto:info@cruzpro.com)

## VERY IMPORTANT Notes

a) **Warning** - Selecting either the USA or European default sender data (page 18) will erase all the previous calibration information! Don't do this after you calibrate -the calibration process automatically corrects for USA or European senders.

b) An error during calibration will require you to start over or use the data editor to correct the problem.

c) The maximum number of calibration points is 20.

d) The sender resistance (output voltage) must change between each calibration point or the FU60 will not work correctly. See [www.cruzpro.com/centroid.html](http://www.cruzpro.com/centroid.html) for setting up Centroid capacitive senders.

e) You cannot enter the calibration data manually, only use the editor to view or change the data (see page 17).

**Page 19**

## Specifications

**Power supply:** 9.5 to 33.0 VDC, .035 amps nom.

**Operating temperature:** 32 to 122 F ( 0 to 50 C)

**Size:** 2.5" dia X 4.1" deep (61mm x 104 mm)

**Accuracy:** Better than 2%, front panel adjustable

**Senders:** Works with most 0-70, 0-90, 10-180 and 30-250 ohm fuel level senders by VDO, Teleflex, GM, Stewart-Warner, Mercury, Faria, and others (both American and European styles).

**Alarms:** 85 db internal Low and High Fuel alarms, settable from 000.0 to 6553.

**Display:** 4 digits, Liters, Gallons or %, 000.0 to 6553 gallons or liters. Five levels of backlighting.

**Output:** NMEA 0183 4800 baud serial output of Fuel Remaining, Consumption Rate & Trip Fuel Used. Output pin can alternatively be programmed as an external alarm output or as a fuel transfer pump control signal.

**Page 4**

## Fuel/Sender Data Editor Operation

The FU60 software contains a simple but effective data editor that enables you to view and/or change the fuel level vs sender resistance data manually. To enter into the data editor mode, remove power to the FU60. Next, press and hold both the ▼ and ▲ keys while reapplying power until "Pt-0" is displayed.

Use the ▼ and ▲ keys to scroll through the data points at any time that the word "Pt X" is displayed ("Pt 0", "Pt 1", "Pt 2" through Pt20 and the word "dONE").

Press the + key to display the sender resistance for that particular data point. Press the + key again to display the fuel level for that data point. You can use the ▲ and ▼ keys to modify either or both the sender resistance or fuel data when that information is being displayed. Pressing the +

**Page 17**

simultaneously press the ▲ and ▼ keys until you hear a long beep. Your digital fuel gauge should now be working!

Select NMEA, External Alarm or Fuel Transfer Mode To toggle screw terminal pin (C) between NMEA 0183 data output, External Alarm Output or to automatically activate a fuel transfer pump (based on low and high fuel alarm settings), press and hold down both the ▼ and ▲ keys for 10 seconds (until you hear a long beep). When the alarm output or fuel transfer pump is activated, a +5VDC signal (10 mA Max.) is output on terminal (C).

The display shows "dAtA", "E-AL" or "tFEr" to indicate the currently selected mode. In fuel transfer pump mode, the display will flash when the transfer pump is running. The pump will activate when the fuel level drops below the LOW alarm value and turn off when the fuel level reaches the HIGH alarm setting.

**Page 16**

## Installation

*Before starting the installation, please read this entire section first. Be sure to install the bulkhead gasket before you install the instrument. Finger tighten the screws that mount the instrument bracket - do not use tools.*

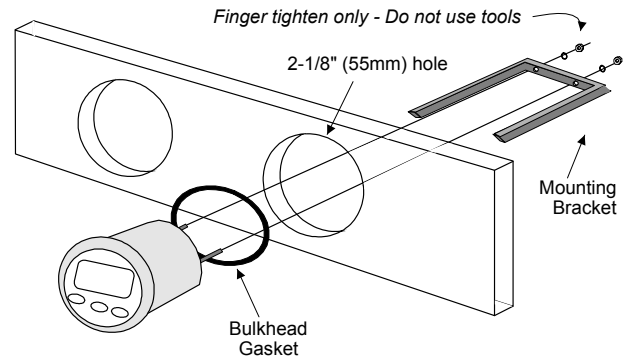

**Figure 1**

**Page 5**

### Step 1

Be sure the fuel tank is empty and apply power to the FU60 while holding down the + key for 3 seconds. The display will show "YES?" to ask if you are sure you want to erase all previous calibration data.

### Step 2

Press the ▲ key to answer YES. Any other key or removal of power stops the process. When you press the ▲ key, you will hear a long beep, all previous data will be erased, the FU-60 will enter calibration mode and blink the number "1".

### Step 3

Pump fuel until the tank is approximately 1/16th full. For example, if you have a 120 gallon fuel tank,

**Page 14**

driver to make the connections to the screw terminal on the instrument case back as shown in figure 2.

- Carefully check all your wiring against those shown in figure 2. If everything is wired correctly you can mount the FU60 in the instrument hole. Be sure the bulkhead gasket is in place and use only finger tension to tighten the bracket hold-down nuts *Do not overtighten the bracket or you may damage the case - do not use tools to tighten the nuts.*

**Page 7**

## Mounting and Wiring

- Drill a 2-1/8" (55mm) mounting hole where you desire to mount the instrument (Figure 1).
- Bring the sender wires, ground, and power lines out of the mounting hole and use a small flat screw-

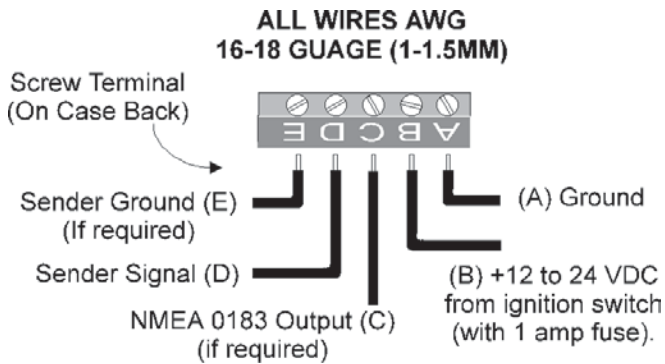

Page 6

Figure 2

## Operation

### Key Functions

The ▼, +, and ▲ keys are used to select backlight levels, display fuel remaining (in liters, gallons or percent), fuel used or fuel consumption rate, set the low/high fuel alarms, calibrate the instrument to your tank shape and sender type, select NMEA 0183 output, external alarm output or transfer pump mode and other functions. After changes are made, the new information is automatically saved to a nonvolatile memory.

Page 8

pump approximately  $120/16=7.5$  gallons into the tank. The exact number is not critical. After pumping this amount of fuel use the ▲ and ▼ keys to make the display read the correct number of liters or gallons that have been pumped so far. When the display reads correctly, press and hold the + key until you hear a long beep. A "2" will now blink.

### Step 4

Pump additional fuel till the tank is approximately 2/16th full. For example, if you have a 120 gallon tank, pump an additional 7.5 gallons into the tank for a total of 15.0 gallons. The use the ▲ and ▼ keys to make the display read 15.0 and hold down the + key until you hear a long beep. A "3" will now blink. Continue this process until the tank is full. When the tank is full, instead of pressing the + key,

Page 15

## Setup and Calibration

The FU60 will display the words "NEEd CAL" on power-up until the gauge has been calibrated to your tank. During the calibration process the FU60 "learns" the tank shape and fuel sender characteristics automatically (USA or European). This information will be saved to memory and needs to be done only once.

For best accuracy this process requires that the fuel tank be empty at the start (if not, the remaining fuel will be a reserve when the gauge shows empty) and involves filling the fuel tank completely. While filling the tank, you will stop a number of times (approximately 16 times, 20 maximum) and tell the FU-60 how much fuel has been pumped into the tank at each calibration point.

*We recommend strongly that you practice this procedure several times without emptying or filling the tank to get familiar with the process. You do not have to have a fuel sender attached.*

Page 13

of time the consumption rate will become more accurate. The consumption rate is an average rate calculated by dividing liters or gallons used by the total trip time and displayed as liters/hr or gallons/hr. To get a more instantaneous reading of fuel consumption, remove and reapply power to the instrument or press and hold the ▼ key for ten seconds while viewing fuel consumption. The trip timer will be reset to zero (as will the trip fuel) and a fresh consumption rate calculation will be made.

#### Checking "Time-To-Go" at Current Consumption Rate

Press both the + and ▲ keys to display how much time you have remaining in hours and minutes (hh:mm) at the current fuel consumption rate before you run out of fuel. A value of 99 hours and 59 minutes is displayed if more than 100 hours of running time remains.

**Page 12**

#### Backlight Intensity

Press the + key for 1/2 second to adjust the backlight level for nighttime viewing. Each time you press the + key for 1/2 second, the backlight level will change: 1, 2, 3, 4, OFF, 1, 2, ... etc.

#### Setting Low/High Fuel Alarms

While viewing Fuel Remaining, press and hold the ▼ or ▲ key for ten (10) seconds to view/set the Low or High fuel alarm setting respectively. You will hear a long beep and the appropriate alarm value is displayed. Use the ▲ and ▼ keys to set the desired fuel alarm limit (000.0 to 6553 liters or gallons). Holding the ▲ or ▼ keys will scroll the values faster. Press the + key for 1/2 second to save your entry to the nonvolatile memory.

**Page 9**

of time the consumption rate will become more accurate. The consumption rate is an average rate calculated by dividing liters or gallons used by the total trip time and displayed as liters/hr or gallons/hr. To get a more instantaneous reading of fuel consumption, remove and reapply power to the instrument or press and hold the ▼ key for ten seconds while viewing fuel consumption. The trip timer will be reset to zero (as will the trip fuel) and a fresh consumption rate calculation will be made.

#### Checking "Time-To-Go" at Current Consumption Rate

Press both the + and ▲ keys to display how much time you have remaining in hours and minutes (hh:mm) at the current fuel consumption rate before you run out of fuel. A value of 99 hours and 59 minutes is displayed if more than 100 hours of running time remains.

**Page 12**

#### Backlight Intensity

Press the + key for 1/2 second to adjust the backlight level for nighttime viewing. Each time you press the + key for 1/2 second, the backlight level will change: 1, 2, 3, 4, OFF, 1, 2, ... etc.

#### Setting Low/High Fuel Alarms

While viewing Fuel Remaining, press and hold the ▼ or ▲ key for ten (10) seconds to view/set the Low or High fuel alarm setting respectively. You will hear a long beep and the appropriate alarm value is displayed. Use the ▲ and ▼ keys to set the desired fuel alarm limit (000.0 to 6553 liters or gallons). Holding the ▲ or ▼ keys will scroll the values faster. Press the + key for 1/2 second to save your entry to the nonvolatile memory.

**Page 9**

### Enabling/Disabling Alarms

Press the ▲ or ▼ key for 1/2 second to "arm" or "disarm" the fuel alarms. The display will flash "On" or "OFF" briefly to show you the state of the alarms. You should normally leave the alarms armed at all times and only disarm them to silence the alarm buzzer temporarily.

### Checking Fuel Remaining

Press the + key to display fuel remaining. You will see either liters remaining or gallons remaining, depending upon how you calibrated the instrument (see "Setting Up and Calibration"). Press the ▲ key to display fuel remaining in percent (0 to 100%).

**Page 10**

### Checking Total Fuel Used or Trip Fuel Used

Press the ▼ and ▲ keys simultaneously to display how much total fuel has been used since last refilling the tank (how much fuel will be required to fill the tank).

Press the ▼ key to display how much fuel you have used in liters or gallons THIS trip. Trip Fuel Used automatically resets to zero every time you disconnect power from the instrument.

### Checking/Resetting Fuel Consumption Rate

Press the ▼ and + keys simultaneously to display how many liters or gallons of fuel you are using per hour. The Fuel Consumption Rate display can be very inaccurate if you have used only a small amount of fuel over a short period of time. As you use more fuel over a longer period

**Page 11**

### Enabling/Disabling Alarms

Press the ▲ or ▼ key for 1/2 second to "arm" or "disarm" the fuel alarms. The display will flash "On" or "OFF" briefly to show you the state of the alarms. You should normally leave the alarms armed at all times and only disarm them to silence the alarm buzzer temporarily.

### Checking Fuel Remaining

Press the + key to display fuel remaining. You will see either liters remaining or gallons remaining, depending upon how you calibrated the instrument (see "Setting Up and Calibration"). Press the ▲ key to display fuel remaining in percent (0 to 100%).

**Page 10**

### Checking Total Fuel Used or Trip Fuel Used

Press the ▼ and ▲ keys simultaneously to display how much total fuel has been used since last refilling the tank (how much fuel will be required to fill the tank).

Press the ▼ key to display how much fuel you have used in liters or gallons THIS trip. Trip Fuel Used automatically resets to zero every time you disconnect power from the instrument.

### Checking/Resetting Fuel Consumption Rate

Press the ▼ and + keys simultaneously to display how many liters or gallons of fuel you are using per hour. The Fuel Consumption Rate display can be very inaccurate if you have used only a small amount of fuel over a short period of time. As you use more fuel over a longer period

**Page 11**