

Warranty

Each unit is carefully tested and adjusted at the factory before shipping and is warranted for one full year against original defects in materials or workmanship. This warranty does not include damage to the product resulting from accident or misuse.

If the product should become defective within the warranty period, we will repair or replace it free of charge, including free return transportation, provided it is delivered prepaid to the dealer from whom it is originally purchased.

This warranty gives you specific legal rights, and you may also have other rights which vary from state to state, or country to country.

GD20B



Handbook

Warranty

Each unit is carefully tested and adjusted at the factory before shipping and is warranted for one full year against original defects in materials or workmanship. This warranty does not include damage to the product resulting from accident or misuse.

If the product should become defective within the warranty period, we will repair or replace it free of charge, including free return transportation, provided it is delivered prepaid to the dealer from whom it is originally purchased.

This warranty gives you specific legal rights, and you may also have other rights which vary from state to state, or country to country.

GD20B



Handbook

Other CruzPro Products

- | Depthsounders & Speed/Temperature/Log
- | DC Volts/Amps/Amp-Hour Monitor
- | AC Volts/Amps/Freq/kW Monitor
- | LPG/Petrol Gas Detectors/Alarms
- | Bilge Water Alarms & Bilge Pump Controllers
- | Windlass Controller/Chain Counter
- | Digital Fuel Gauge & Fuel Consumption Calculator
- | Digital Gauge for Three Tanks /w Separate Alarms
- | Smart and Manual Alternator Regulators
- | Marine Security System
- | RPM/Engine Hours/Elapsed Time Gauge
- | Digital Oil Pressure Gauge/Alarm
- | Digital Water Temperature Gauge/Alarm
- | One and Three Bank Digital Volts Gauges
- | Digital Amps Gauge
- | Digital Clock/Watch/Race Timers/Alarms
- | 8 and 16 Amp Light Dimmers / Motor Speed Controller
- | Solar Panel Charge Controllers 6/8/9 & 20 Amps
- | 4 & 8 Channel NMEA Combiners/RS-232 Convertors
- | Engine/Exhaust Temp. Monitor & Digital Pyrometer
- | NMEA 0183 Remote Data Repeater/w 4 Input Channels
- | NMEA 0183 Multiplexer (4 and 8 channel versions)
- | Digital Rudder Angle Indicator

See full details at <http://www.cruzpro.com>

Email to: info@cruzpro.com

Page 18

memory. After five minutes the GD20B will wake itself, warm the sensor(s) for 45 seconds and then test for dangerous levels of gas for fifteen seconds. If all is OK it will go back to sleep for another five minutes.

If the gas concentration is above the sensitivity threshold level when the GD20B wakes up, the GD20B will sound the alarm and behave in the normal fashion. If this should happen, the GD20B will monitor gas concentrations continuously and not go back to sleep until told to do so.

If the GD20B is asleep and you wish to wake it manually, press the "test" button. The GD20B will waken immediately and not go back to sleep until told to do so.

The UP and DOWN buttons still control the LPG solenoid while the GD20B is in sleep mode.

Page 16

Table of Contents

Introduction	4
Specifications	7
Installation	8
Operation/Testing	12
Warning Notes	17
Other CruzPro Products	18
Warranty	Back Cover

©1997 BV Engineering GD20BMANH

Page 3

soon as the gas vapor has subsided.

The GD20B uses new technology to lower the power requirements for the sensor and the GD20B can be programmed to put itself to sleep for further power conservation. The GD20B can be programmed to be active continuously or wake up every 5 minutes for a sniff. If the GD-20B senses a dangerous concentration of gas, it sounds the alarm, cuts power to the LPG solenoid and deactivates sleep mode to continuously monitor the situation.

You can use the UP and DOWN buttons on the GD20B to manually turn your LPG solenoid ON and OFF. You can also program the GD20B to automatically turn off the LPG solenoid one hour after you turn it on, just in case you forgot to do so yourself. You get a warning beep and then have 5 minutes to press the UP button (if you need another hour).

A built-in self test program checks the electronics

Page 5

Introduction

LPG or gasoline/petrol vapors, even in low concentrations, make a dangerous heavier-than-air explosive mixture that can settle in low areas of your boat's bilge. The GD20B Gas Vapor Monitor detects gas vapors at very low concentrations and warns you before they reach dangerous levels.

The GD20B can detect gas vapors at approximately 10%, 20% or 30% of LEL (Lower Explosive Limit), the concentration required for an explosion. The desired sensitivity can be selected from the front panel and stored in the non-volatile memory. When activated, the GD20B built-in 85 dB alarm will sound and, (if desired), remove power to your LPG solenoid automatically.

The alarm will continue to sound as long as the sensor detects a dangerous concentration of gas vapor or until the "Wait" button is pressed. If the alarm is silenced by the use of the Wait button, the GD20B will automatically re-arm the alarm as

Page 4

Warnings Notes

Detectable Vapors: The GD20B sensor detects alcohol, butane, gasoline/petrol, hydrogen, kerosene, LP gas, propane, and methane. Common cleaning agents and aerosol spray cans contain vapors that can also activate the GD20B alarm.

LEL: Each gas has its own LEL (Lower Explosive Limit). The GD20B is calibrated against LPG.

Sensor Contamination: Aerosols from paints, silicone vapors, and corrosive gasses such as hydrogen sulfide and sulphur dioxide can deteriorate the gas sensor used by the GD20B. If you cover the sensor to protect it during painting, varnishing, etc., be sure to leave a note to uncover them later.

Sensor Replacement: Sensors do deteriorate over time, especially in very humid environments. You should check or replace your sensor every 2 to 3 years. A calibrated gas is required to test the sensors - do not use large quantities of full strength gas to test it - you can burn the sensor. The GD27 is the correct replacement sensor for the GD20B.

Page 17

and wiring to the gas sensor(s) automatically in less than one minute and reports any problems.

The GD-20B operates from any voltage between 10.5 VDC and 30.0 VDC.

In addition to the built-in 85 dB alarm, the GD20B provides an alarm output that can be connected to the optional LA-20 External Loud Alarm to provide an amazing 105 dB of volume. This amount of noise can be heard for 1/4 mile or more.

The GD-20B comes with one LPG sensor and an optional second GD27 LPG or gasoline/petrol sensor can be connected. All mounting hardware is provided and installation only requires a screwdriver.

All CruzPro instruments are constructed of ABS plastic, stainless steel hardware, solvent resistant gaskets, Lexan brand polycarbonate and 3M adhesives to insure a reliable long life in the harsh marine environment.

Page 6

should take the GD20 and it's sensor(s) to your dealer for repair or replacement.

You should exercise the self test feature often. It is most accurate after the sensor has been on for a while (the heat cleans the sensor). In addition to testing the internal electronics and the sensor(s), the self-test can pick up on any broken wires between the GD20B and it's sensor(s). The optional second sensor will not be recognized until you perform a self test.

To test the sensors you can use an unlit butane cigarette lighter and direct some of the gas towards the sensor (see warning note on page 17).

Sleep Mode: You can minimize the power drain on your batteries by telling the GD20B to go to sleep and wake itself every five minutes for a sniff. To enable the sleep mode, press the DOWN key for three seconds. You will hear a beep and the green "Safe" light will flash briefly once per second indicating the GD20B is asleep. The sleep mode is automatically saved to non-volatile

Page 15

Specifications

Setting the Sensitivity: The GD20B comes factory set with the sensitivity set to approximately 20% of LEL (Lower Explosive Level). You can select 10%, 20% or 30% LEL by simultaneously pressing and holding the UP and DOWN keys for ten seconds. At ten seconds you will hear a long beep. Release both keys and press either the DOWN, the "Test" or the UP key within five seconds to select approximately 10%, 20% or 30% LEL sensitivity. This setting is automatically saved to non-volatile memory.

Testing the GD20B and the Sensor(s): If you press and hold the "Test" button for ten seconds, the GD20B will enter the self-test mode. All three of the lights will flash alternately as the GD20 checks itself out as well as testing the sensor(s) and wires. If all is well, the green Safe light will light after about 45 seconds.

If there is a problem, the Alarm and Wait lights will flash alternately and the alarm buzzer will sound for 3 seconds. If this should happen, you

Page 14

Power supply: 10.5 to 30.0 VDC, 0.085 amps @ 13.8 VDC, 0.055 amps @ 24 VDC.

Sleep mode: Program to wake up every 5 minutes for a sniff, cuts average current to .020 amps.

Sensitivity: Front panel selectable. Approximately 10%, 20%, or 30% LEL (Lower Explosive Level)

Operating temperature: 0 to 50 deg Celsius (32 to 122 deg Fahrenheit).

Size: 100 x 60 x 30 mm (4 x 2.4 x 1.2 inch).

Alarms: Internal 85 dB at 30 cm (12 inches), flashing red LED indicator. Output for optional external 105 dB alarm (LA-20).

Solenoid Control: Automatically deactivate LPG solenoids drawing up to 3 amps. The GD-20 may be used to turn solenoid on/off manually as well. Auto shutoff after one hour (if desired).

Sensor: One GD27 LPG/Petrol sensor standard. Second GD27 sensor (LPG/Gasoline/Petrol) optional.

Page 7

Operation/Testing

Normal Operation: When the power is applied to the GD20B Gas Vapor Monitor, you will hear two short beeps and the red "Wait" light will go on. After 45 seconds, the wait light should go out and the green "Safe" light will go on if the gas concentration is at safe levels. If your LPG solenoid is wired to the GD20B, you can turn it on or off at any time by pressing the UP and DOWN arrow keys.

LPG Solenoid: If you press the UP arrow key, the solenoid will turn ON and the "Wait" light will flash briefly once per second (indicating that the LPG solenoid is ON). If you press the DOWN arrow key, the LPG solenoid will turn OFF. If you do not turn off the solenoid yourself the GD20B will do it for you automatically. After 55 minutes the GD20B gives you a 5 minute warning (5 short quick beeps) and turn off the LPG solenoid five minutes later. At any time you can restart the one hour timer by briefly pressing the UP arrow.

If you do not want the GD20B to automatically

Page 12

case front and align the case back onto any suitable surface. Using the case back as a drill guide, mark the location of the two mounting holes with a soft pencil lead. Remove the case back and drill two 2mm (3/32 inch) holes where indicated. Mount the case back using the two countersunk screws.

The GD-20B comes with a GD27 LPG/gasoline/petrol sensor cable. Both the sensor cable and the power/solenoid-control cable are threaded through the rubber grommet at the bottom of the instrument.

After the sensor(s) and the GD-20B case have been mounted in suitable locations, make all the electrical connections as shown in Figure 1 EXCEPT for the red power connection from the GD20B to your battery. 1.0 mm diameter (#18 gauge) wire should suffice for both the power cable and the solenoid connection. Make the positive (red wire) connection from the GD20B to your battery last. When you make the last battery connection the GD20B should beep twice and the Wait light should light.

Page 9

Installation

Before starting the installation, please read this entire section and the "Warning Notes" section. Get professional help if you do not fully understand these instructions.

The GD-20B case is not water-proof and must be located in an area that will not get wet. The sensor(s) should be mounted as low as possible while insuring that bilge water cannot reach them. The sensor(s) will be permanently damaged if immersed in water.

If your boat has more than one enclosed area, you should mount a second sensor to provide coverage for that area as well. See Figure 1 for the proper connection points for the second sensor. If you are wiring the optional second sensor to the screw terminals, be sure that there are no exposed loose strands of wire that might later cause a short and do not overtighten the screw terminals.

After mounting your sensor, remove the GD-20B

Page 8

turn off your LPG solenoid, press and hold the UP arrow for 3 seconds (until you hear a long beep). The solenoid will stay on until you (or the gas alarm) turns it off. You can do this at any time.

Gas Vapor Alarm: If gas concentrations reach the alarm level, the "Safe" light will go out, the red "Alarm" light will blink and the built-in 85 dB alarm buzzer will sound. If the LPG solenoid was ON, the GD20B will turn it off automatically.

The alarm will continue to sound until the gas concentration falls below the detection threshold or you disable the alarm by pressing the "Test" button. If you disable the alarm, it will automatically re-arm when the gas concentration drops below the threshold level.

When the gas concentrations drops below the alarm threshold, the alarm will silence but the Alarm light will continue to blink briefly once per second to tell you the alarm had gone off. Pressing the "Test" button (after the gas concentration has dropped) will turn off the blinking Alarm light.

Page 13

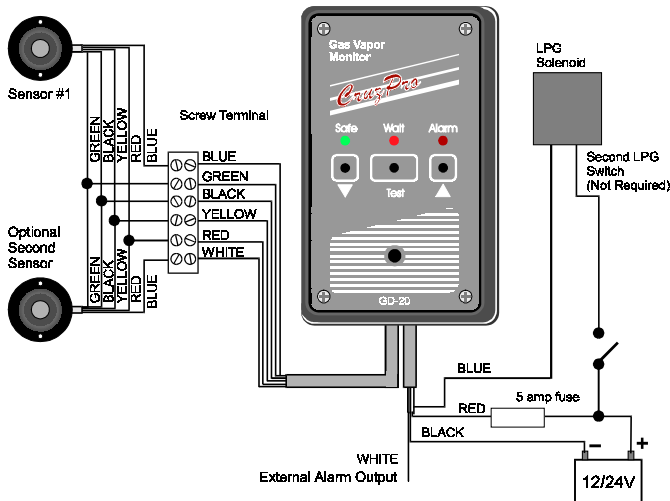

Figure 1
GD20 Connection Diagram

The second LPG Solenoid Switch is not required but might already be wired into your system. If you use the second switch, both the GD20B and the second switch must be ON before the LPG solenoid is activated, but either can turn the solenoid

Page 10

OFF.

Carefully check all your wiring against those shown in figure 1.

After installing your GD-20B Gas Vapor Monitor, you should check for proper operation as described in the "Operation/Testing" section.

Page 11