

- PC Based Fishfinder/Sonar for Windows
- Speed Over Ground GPS based Paddle Wheel Substitute
- Ultrasonic 3D Wind Speed/Direction Sensor
- Wind Speed/Direction Display
- Precision Seawater Temperature Gauges
- Digital Timer/Switch to Turn On/Off Multiple Circuits
- Multi-Function Instruments

CruzPro®

HA60



Digital Heel Angle Gauge and Alarm

Page 1

www.cruzpro.com Email: info@cruzpro.com

Notes and Warnings

- Screw terminal "E" at the back of the instrument is used for external backlight ON/OFF control. If external backlight ON/OFF control is not required, you should permanently connect terminal "E" to +12/24 VDC or the backlights will not work.
- Screw terminal "D" is not used. Do not connect.
- Screw terminal "C" can be programmed to be either a NMEA 0183 serial data output or as an external alarm output. In either case, the signal is 0 to +5V in series with a 270 ohm resistor.

Introduction

The HA60 digital Heel Angle Gauge displays Heel Angle, Maximum Port Heel Angle and Maximum Starboard Heel Angle from -40.0 to +40.0 degrees with a resolution of 0.1 degree.

A high angle alarm can be set and the display will flash when the angle alarm is activated. If enabled, the HA60 built-in 85 dB alarm will also sound.

Five levels of backlighting can be selected and all values are saved to a non volatile memory.

Data is output on an NMEA 0183 compatible serial data output or you can select to use this output line as an External Alarm Output.

Table of Contents

Introduction	3
Specifications	4
Installation	5
Mounting and Wiring.	6
Operation	8
Key Functions	8
Backlight Intensity	9
Turning Alarms On/Off	9
Setting a Heel Angle Alarm	10
Selecting NMEA 0183 or External Alarm Output	11
Selecting Heel Angle or Filtered Heel Angle	12
Viewing/Setting the Filter Factor	12
Zero the Heel Angle	12
Displaying Maximum Port or Starboard Heel Angle	13
Reset Maximum Heel Angle Memories.	13
Notes and Warnings	14
Other CruzPro Products	15

©2020 CruzPro Ltd. HA60MANE
http://www.cruzpro.com Made in New Zealand

Specifications

Power supply: 9.5 to 33.0 VDC, .035 amps nom.

Operating temperature: 32 to 122 F (0 to 50 C)

Size: 2.5" dia X 4.1" deep (61mm x 104 mm)

Accuracy: Better than +/- 1 degree.

Alarms: A heel angle alarm is settable from 0 to 40 degrees..

Display: 4 digits. 5 levels of backlighting.

Data output: NMEA 0183 serial data output . If NMEA output is not needed, the data output pin can be programmed as an External Alarm Output.

Sample NMEA sentences:

\$IIXDR,A,-012.7,D,HA60*73 (Port Angle)

\$IIXDR,A,000.4,D,HA60*6E (Starboard Angle)

Other CruzPro Products

- Depthsounders & Speed/Temperature/Logs
- AC & DC Volts/Amps/Amp-Hour/Freq/kW Monitor
- LPG/Petrol Gas Detectors/Alarms
- Digital Fuel Gauge & Fuel Consumption Calculator
- Bilge Water Alarms & Bilge Pump Controllers
- Windlass Controller/Chain Counter
- Remote NMEA 0183 Digital Data Repeaters
- Smart Alternator Regulators
- Marine Security System
- RPM/Engine Hours/Elapsed Time Gauge
- Digital Oil Pressure & Water Temperature Gauges/Alarm
- Digital Tank Level Gauge/Alarms for Three Tanks
- One and Three Bank Digital Volts Gauges
- Digital Amps Gauge
- Digital Clock/Watch/Race Timers/Alarms
- 8 and 16 Amp Light Dimmers / Motor Speed Controller
- Solar Panel Charge Controllers
- 4 & 8 Channel NMEA Combiners/RS-232 Convertors
- Engine/Exhaust Temp. Monitor & Digital Pyrometer
- Remote NMEA 0183 Data Repeater/w 4 Input Channels

Display the Maximum Port or Starboard Heel Angle

Quick press both the ▼ and + keys to display the Maximum Port Heel Angle seen since last reset. Press the + key to return to the previous mode.

Quick press both the + and ▲ keys to display the Maximum Starboard Heel Angle seen since last reset. Press the + key to return to the previous mode. .

Reset Maximum Heel Angle Memories.

Press and hold both the ▼ and ▲ keys for 10 seconds (untill you hear a long beep) to reset both the Maximum Port and Starboard Heel Angle memories to zero.

Selecting Heel Angle or Filtered Heel Angle

Quick press the **+** key to display instantaneous Heel Angle. Quick press both the **▼** and **▲** keys to display Filtered Heel Angle. The mode is automatically saved to the non-volatile memory.

Viewing/Setting the Filter Factor

Hold the press **▲** key 10 seconds to View the Filter factor (0 to 20). The higher the number the more filtering. Use the **▼** and **▲** keys to change. Quick press the **+** key to save the new value.

Zero the Heel Angle

Press and hold the **+** key for 10 seconds (until you hear a long beep) to zero the display when not heeled.

Installation

Before starting the installation, please read this entire section first. Be sure to install the bulkhead gasket before you install the instrument. Finger tighten the screws that mount the instrument bracket - do not use tools.

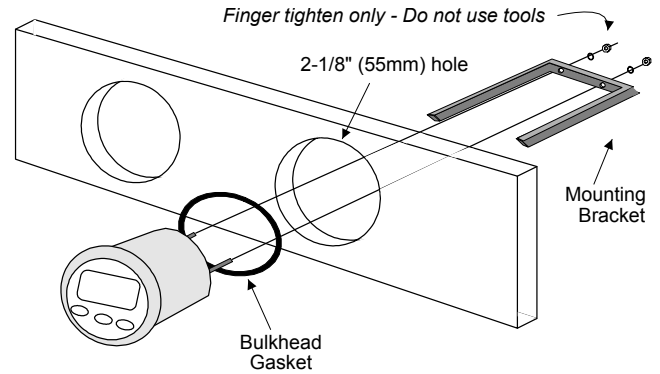

Figure 1

Setting a Heel Angle Alarm Value

While viewing Angle, press and hold the **▼** key for ten seconds. (until you hear a long beep). The Heel Angle Alarm value will be displayed. Press the **▼** and **▲** keys to set the desire alarm value (0 to 40 degrees). Holding either key will cause the display to change more quickly. Press the **+** key to save your entry.

driver to make the connections to the screw terminal on the instrument case back as shown in figure 2.

- Carefully check all your wiring against those shown in figure 2. If everything is wired correctly you can mount the HY60 in the instrument hole. Be sure the bulkhead gasket is in place and use only finger tension to tighten the bracket hold-down nuts *Do not overtighten the bracket or you may damage the case - do not use tools to tighten the nuts.*

Mounting and Wiring

- Drill a 2-1/8" (55mm) mounting hole where you desire to mount the instrument (Figure 1).
- Bring the sender wires, ground, and power lines out of the mounting hole and use a small flat screw-

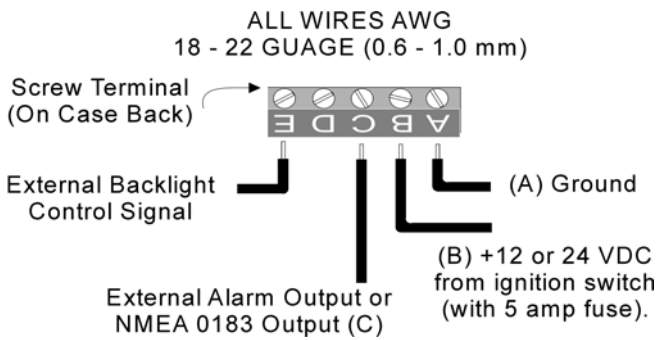

Figure 2

Operation

Key Functions

The ▼, +, and ▲ keys are used to select backlight levels, display Heel Angle, Maximum Port or Starboard Heel Angle, set a Heel Angle Alarm, activate/deactivate the alarms and select to output either NMEA 0183 serial data to use screw terminal 'E' as an external alarm output.. After changes are made, the new information is automatically saved to non volatile memory.

Selecting NMEA 0183 or External Alarm Output

The HA60 comes factory preset to use screw terminal pin C as an External Alarm output. To switch between External Alarm and NMEA 0183 modes:

While viewing Angle, press and hold down both the ▼ and + keys for 10 seconds (until you hear a long beep). This operation switches the output mode between NMEA 0183 and External Alarm. The display will show "dAtA" or "EA". The new output mode is automatically saved to memory.

When the external alarm output is activated, a 5V signal (10 mA Max.) is output on screw terminal C.

Backlight Intensity

Press the + key for 1/2 second to adjust the backlight level for night time viewing. Each time the level will get brighter 1, 2, 3, 4, OFF, 1, 2, ... etc. Screw terminal "E" at the back of the instrument provides external backlight ON/OFF control and must be connected to +12/24 VDC to enable the backlights. If you do not need external backlight control, permanently connect terminal "E" to +12/24 VDC

Turning Alarms ON/Off

Press the ▲ or ▼ key for 1/2 second to "arm" or "disarm" the alarms.